

## Profiler II DC Motor Control Board with Current Profiling Capability

The Profiler II is a DC Motor Control board designed specifically for *Motion Systems Corp.* © motor drives. This innovative new control board provides safe, intelligent bi-directional control for brush type DC motor drives up to 20 Amps.

What sets the Profiler II apart from other motor drives is its intelligent, self-learning and adjusting operation. The Profiler II actually learns the characteristics of the drive system in just 2 simple operations. During the first operation, the Profiler II learns the amount of travel time required to run the drive system to full extension in each direction of travel. The run times are then stored permanently in nonvolatile memory. In the second operation, the Profiler II automatically builds two, fifty point, power versus travel time profiles (see figure 1), one for each direction of travel. The profiles are a direct representation of the DC motor drive's characteristics for each direction of travel. These profiles are then also stored permanently in nonvolatile memory, and are used as a dynamic reference for over-current shut down (see figure 2).

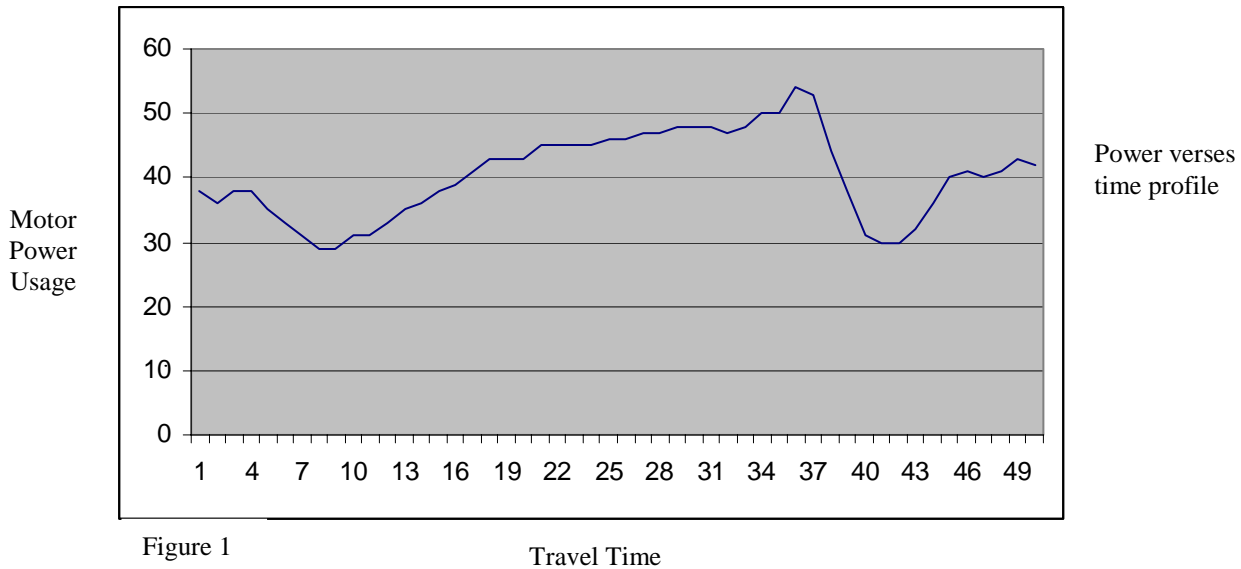

Figure 1

Travel Time

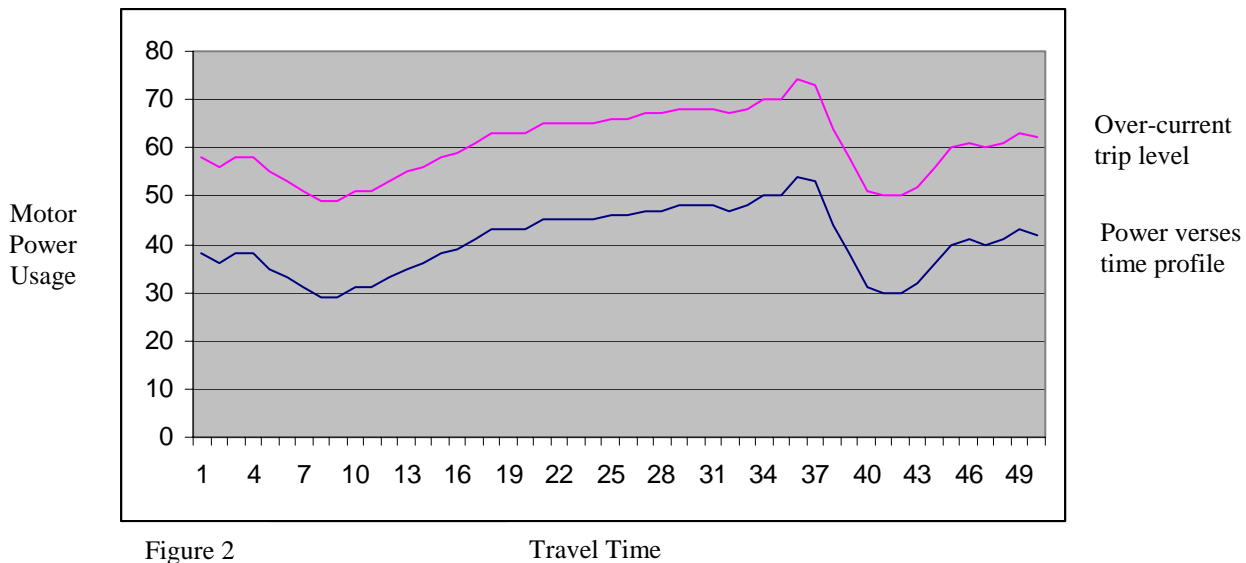

Figure 2

Travel Time

The Profiler II's Power Profiling technology provides for very sensitive blockage protection with no external sensors. This keeps the cost and complexity of the system to a minimum.

The over-current trip level directly correlates to the power versus time profile. This allows for very sensitive trip protection without affecting the reliability of the motor drive system. The over-current trip protection feature will stop the motor drive and reverse direction if a trip event occurs. This is done to prevent injury and allow for the path to be cleared should an object obscure the normal path of operation.

The Profiler II is designed specifically for *Motion Systems Corp.* © motor drives with end of travel free-run capability. This creates a failsafe, allowing the motor to free-run when the end of travel is reached in either direction without damaging the mechanics of your system or the motor drive. Use of the Profiler II with non free-run motors is not recommended.

The Profiler II also soft starts the DC motor in each direction. The soft start feature uses pulse width modulation to ease the motor into motion in both directions. This soft start greatly increases the motor brush life and provides smooth system startup performance.

The system is operated using a single momentary push button switch. Simply press and release the control button and the motor will soft start and run in one direction. Press the button again and the motor will soft start and run in the other direction. That's it; the Profiler II does the rest.

The Profiler II also has several additional features.

1. On the fly storage of system control settings. This simply means that once the system is setup, it should never need to be changed again do to power outages. The controller remembers all control states and values so if power is removed the controller picks up where it left off before power was removed. *Note: as a safety feature the controller will never power up in motion. The control button must be pressed after power is reapplied and the controller will return to the direction it came from and then is ready for service again.*
2. The controller stores the setback values if tripped during motion. This feature allows for the power to be shut off after an over current shut down. This would allow for the obstruction to be removed, power reapplied, and the controller would remember that an over current shut down had accrued and would return to the direction it came from without losing track of where it was.

## Setup Procedure

The controller is very easy to initially setup. Simply connect the controller to power, motor drive, and switches (see last page). Then press and hold the set button. Next press and hold the control button, release both buttons after 2 seconds. The motor should soft start and run until it reaches the end of travel and stop. Now press and hold the set button. Then press and hold the control button, release both buttons after 2 seconds. The motor will run until it reaches the end of travel in the other direction. You have now completed the travel time setup for both directions of travel. Now press and release the control button and the motor will run until it reaches the end of travel and you will hear two beeps. Finally press and release the control button and the motor will run until it reaches the end of travel in the other direction and beep twice. This completes the setup procedure. The Controller is now ready for service and should not need setup again. If the drive system is changed or you desire to change the setup simply follow the above procedure again.

The controller board is shown below. There is a 6-pole dipswitch that is used to set the over current trip threshold. The trip threshold is adjustable from 0 to 255 in increments of 4. This allows you to set the trip threshold as close to or far away as you desire from the current profile. Simply stated the trip threshold setting varies the sensitivity of the control board.

32 16 8 4 2 1 SWITCH NUMBER

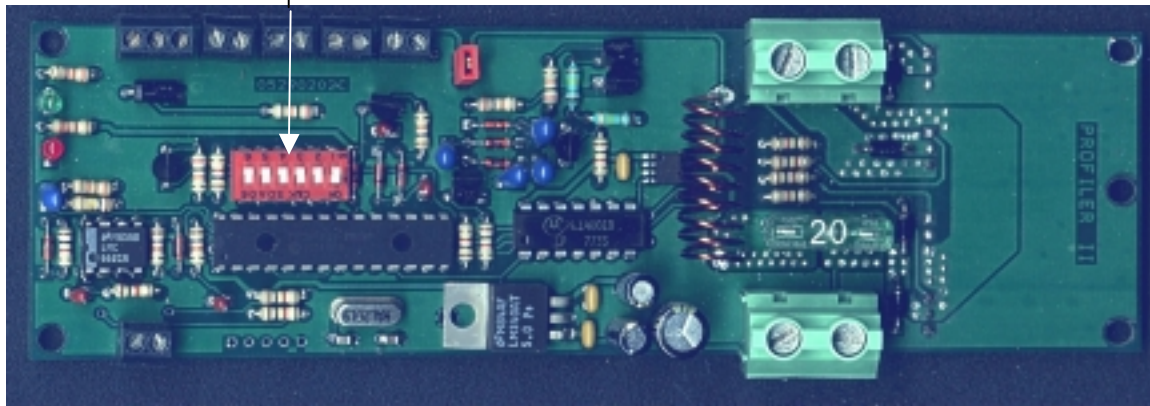
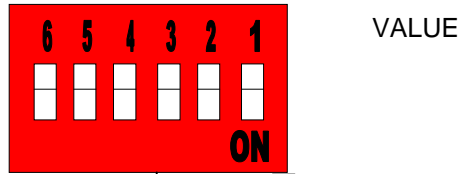

The dipswitch settings are shown in figure 7 below.

Switch number		1	2	3	4	5	6
Dipswitch. value	Trip Value	1	2	4	8	16	32
1	4	on	off	off	off	off	off
2	8	off	on	off	off	off	off
3	12	on	on	off	off	off	off
4	16	off	off	on	off	off	off
5	20	on	off	on	off	off	off
6	24	off	on	on	off	off	Off
7	28	on	on	on	off	off	off
8	32	off	off	off	on	off	off
9	36	on	off	off	on	off	off
10	40	off	on	off	on	off	off
11	44	on	on	off	on	off	off
12	48	off	off	on	on	off	off
13	52	on	off	on	on	off	off
14	56	off	on	on	on	off	off
15	60	on	on	on	on	off	off

16	64	off	off	off	off	on	off
17	68	on	off	off	off	on	off
18	72	off	on	off	off	on	off
19	76	on	in	off	off	on	off
20	80	off	off	on	off	on	off
21	84	on	off	on	off	on	off
22	88	off	on	on	off	on	off
23	92	on	on	on	off	on	off
24	96	off	off	off	on	on	off
25	100	on	off	off	on	on	off
26	104	off	on	off	on	on	off
27	108	on	on	off	on	on	off
28	112	off	off	on	on	on	off
29	116	on	off	on	on	on	off
30	120	off	on	on	on	on	off
31	124	on	on	on	on	on	off
32	128	off	off	off	off	off	on
33	132	on	off	off	off	off	on
34	136	off	on	off	off	off	on
35	142	on	in	off	off	off	on
36	146	off	off	on	off	off	on
37	150	on	off	on	off	off	on
38	154	off	on	on	off	off	on
39	158	on	on	on	off	off	on
40	162	off	off	off	on	off	on
41	166	on	off	off	on	off	on
42	170	off	on	off	on	off	on
43	174	on	on	off	on	off	on
44	178	off	off	on	on	off	on
45	182	on	off	on	on	off	on
46	184	off	on	on	on	off	on
47	188	on	on	on	on	off	on
48	192	off	off	off	off	on	on
49	196	on	off	off	off	on	on
50	200	off	on	off	off	on	on
51	204	on	in	off	off	on	on
52	208	off	off	on	off	on	on
53	212	on	off	on	off	on	on
54	216	off	on	on	off	on	on
55	220	on	on	on	off	on	on
56	224	off	off	off	on	on	on
57	228	on	off	off	on	on	on
58	232	off	on	off	on	on	on
59	236	on	on	off	on	on	on
60	240	off	off	on	on	on	on
61	244	on	off	on	on	on	on
62	248	off	on	on	on	on	on
63	252	on	on	on	on	on	on

# Electrical hookup

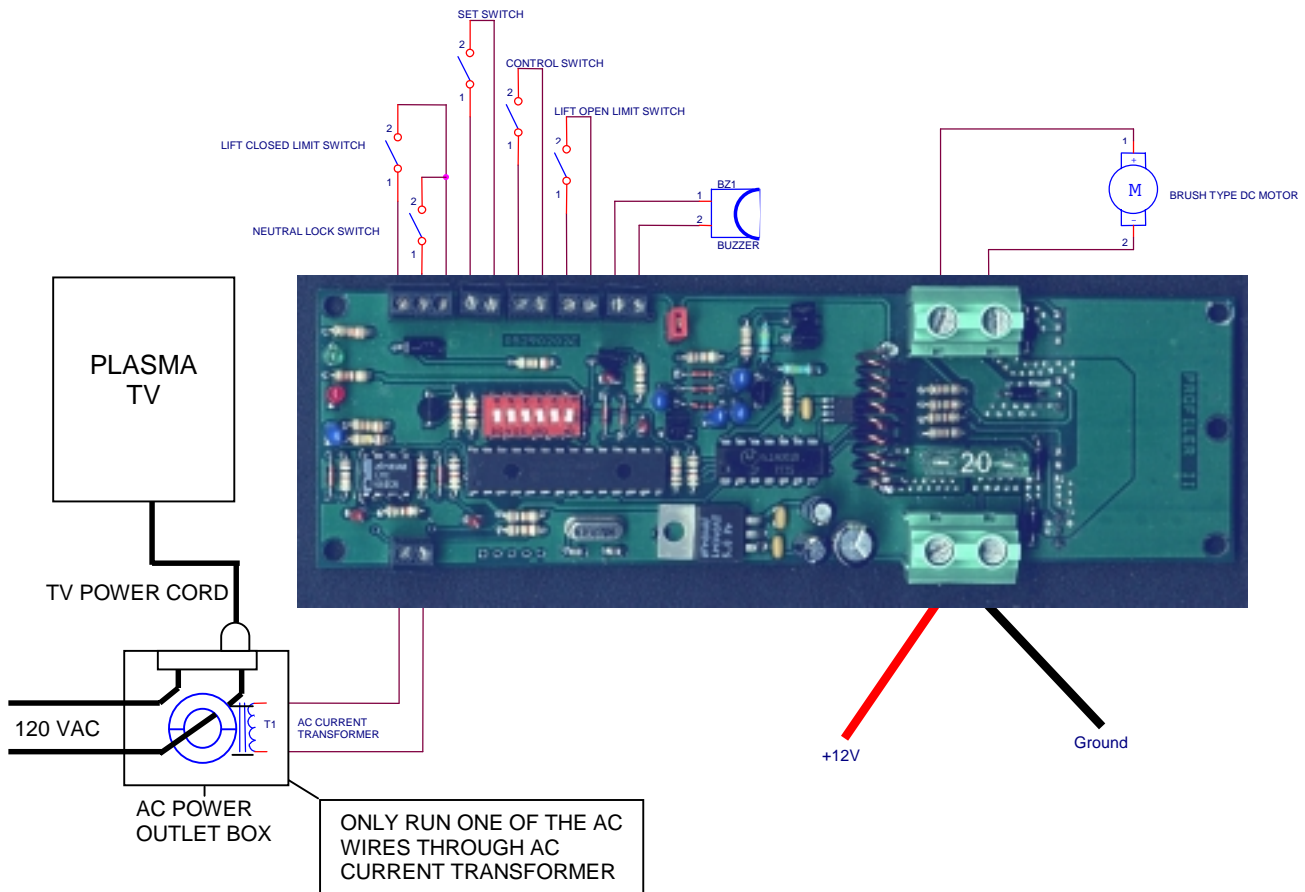

The electrical connections shown above are for a typical installation.

The AC current transformer should be clamped over only one of the AC power wires in the outlet box to be used to power TV. The current transformer never physically connects to the AC power wire. This makes it totally safe. Power required by the TV is transferred to the current transformer and provides a very low level AC voltage to the Profiler II. The low AC voltage is all the Profiler II needs to know if the TV is on or off.

**Please use twisted pair or shielded audio cable for all remote switch connections.**

The set switch is normally left disconnected or placed in a hidden location.

The control button can be placed anywhere it's required.

The lift open and closed limit switches, and motor are wired at factory.

**\*Please pay special attention to the polarity of the power wires. If power is connected backwards serious damage will result to Profiler II.**

